

Step 2 - Levelling the Cabinet and Tank.

TO ENSURE LONG TERM STABILITY OF YOUR AQUARIUM ONCE IT IS FILLED, IT IS OF PARAMOUNT IMPORTANCE THAT THE CABINET AND TANK ARE CORRECTLY LEVELLED USING THE ADJUSTABLE FEET ON THE BASE OF THE CABINET, AS THIS ENSURES THAT THERE IS NO STRESS ON THE GLASS AND THAT THE DOORS WILL HANG SQUARE.

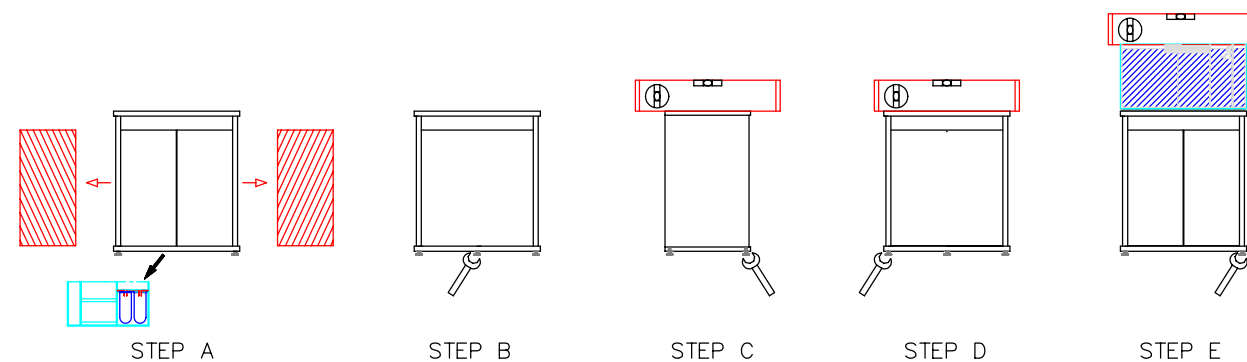

NOTE: Once in position against a wall, the feet in the centre at the back of the cabinet will be hard to access and adjust and so it is important that the cabinet is adjusted around these feet first. The same applies to any feet that are inaccessible in a corner.

Equipment Required

Spirit level (the longer the better), 12mm spanner, 17mm spanner.

Preparation

Ensure that the area where the tank is to be installed is clear so that you have plenty of space for installation and adjustment. The cabinet should be initially levelled without the tank or sump installed and we recommend that you remove the quick release doors for better access by pressing the lever at the back of each hinge. When the tank is delivered the feet will normally be screwed all the way into the cabinet. If this is not the case then screw the feet fully home to give the greatest range of adjustment.

Start by establishing if your floor is level by placing the cabinet roughly in position and checking the level using the spirit level on the top of the cabinet.

Cabinet is lower at back

If the cabinet leans back towards the wall then it will be necessary to extend the rear feet first, especially the centre ones as it will not be easy to adjust them later. Extend the **rear centre** foot/feet to be just higher than the outer rear feet so that the tank is level or leans slightly forward. Lock in position. Adjust the **back centre** foot/feet so that the cabinet is level in the middle front to back. You should be able to slightly rock the cabinet from side to side and the outer four feet should not have weight on them.

Now check the level along the length of the cabinet, you should be able to tip the cabinet so that it is level. If the outer feet touch the floor before it reaches the level then you need to go back a step and extend both front and back centre feet further.

Adjust the four corner feet so that the cabinet is level along the length at both the front and the back by extending the feet down. Check the front to back level at both ends and the middle then make any fine adjustments as necessary. Check the level in both planes on the base of the cabinet and that the centre legs are still touching the floor.

Cabinet is lower at front

If the cabinet is lower at the front it will still be necessary to ensure that the **centre back** feet are touching the floor.

Wind out the **centre back** feet by a few mm to be higher than the two outer back feet and adjust the **front centre** foot/feet so that the cabinet is level in the middle front to back. You should be able to slightly rock the cabinet from side to side and the outer 4 feet should not have weight on them.

Now check the level along the length of the cabinet, you should be able to tip the cabinet so that it is level. If the outer feet touch the floor before it reaches the level then you need to go back a step and extend both centre feet further.

Adjust the four corner feet so that the cabinet is level along the length at both the front and the back by extending the feet down. Check the front to back level at both ends and the middle then make any fine adjustments as necessary. Check the level in both planes on the base of the cabinet and that the centre legs are still touching the floor.

Cabinet is lower at one side

Start by ensuring that the feet on the high end are fully screwed up into the cabinet. Level the cabinet front to back on the **outer feet on the high end** then adjust the two **centre** feet so that the cabinet is level front to back and along the length. Finally screw down the feet on the low end of the cabinet to touch the floor. Check the level on the base of the cabinet and that the centre legs are still touching the floor.

Install the Tank and Sump

After installing the tank and sump but before filling check the level again by placing the spirit level along the edges of the tank and make any fine adjustments as necessary. Fill the tank and sump and again check that the floor has not compressed or settled with the weight and adjust if necessary. Check again after 2-3 days and fine adjust if necessary. Ensure that the locking nuts are screwed up tight against the cabinet.

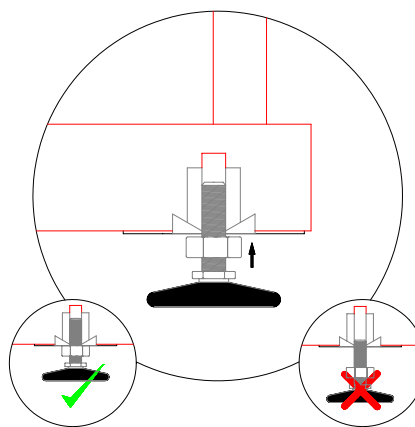

Step 3 - Installing the Pipework, Filters & Overflow.

The pipework and weir system has been specially designed for installation without any further cutting or specialist tools.

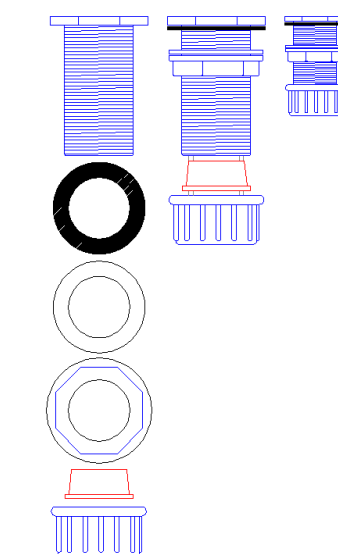

Fitting the Tank Connectors

The tank connectors can be installed with the tank in position however it is much harder to tighten up the nuts on the bottom. For this reason we recommend that, with assistance, you slide the tank so that the weir box hangs over the end of the cabinet, giving you clear access for installation.

The tank connectors should be installed without the use of any silicone sealant or mastic.

Disassemble the tank connector and insert the main body, with the black rubber washer fitted, through the appropriate hole in the overflow box from the top. From below fit the white hard washer and the fastening nut and tighten so that it is firmly hand tight. It is not necessary to use a spanner to over tighten this nut however it must be firm enough so that it cannot come loose later.

If you do not have a large spanner it is often possible to tighten an extra 1/4 turn by tapping the nut round using a flat bladed screwdriver held in one hand on the edge of the nut whilst you tap the handle with the flat of the other hand.

Once all 3 tank connector bodies are firmly fitted, you must once again recruit the help of your friends to carefully lift and slide the tank back into position on the cabinet.

Installing the Pipework

There are 3 pipes that need to be installed, one main syphon pipe fitted with a valve, one emergency overflow pipe and one return pipe from the pump.

Pipe 1. Starting from the right of the tank we will install the smaller return pipe first.

Hold the pipe with the glued hosetail union downwards and slide the knurled nut with the cup pointing upwards onto the pipe.

Next put on the cream tapered seal with the thinner part pointing upwards. From inside the cabinet push the pipe up through the tank connector. Move to the top of the tank and screw the threaded end of the pipe into the 90 degree threaded fitting that is part of the pre-installed pipework in the overflow box. Slide the tapered seal and knurled nut up the pipe inside the cabinet to the tank connector and hand tighten.

The pre-assembled pipework that passes through the overflow wall is threaded and fully removable for cleaning. The removable union on the return pipe allows the pump to be removed for cleaning.

Pipe 2. Moving to the centre pipe, slide the straight pipe down through the tank connector from above. From below slide on the tapered washer and the knurled nut in the same orientation as for pipe 1. Slide the pipe up so that the upper cut end is about 5mm below the horizontal section of the weir comb and tighten up the knurled nut and seal. This will provide the quietest running by reducing trickle as the water flows into the weir box.

Pipe 3. Assemble the third pipe, which is pre-fitted with an adjustable shut off valve, and rotate the pipe so that the arrow on the valve points downwards. Take the remaining knurled nut and tapered washer and fit this to the upper section of the pipe with the cup and thin part of the seal pointing upwards. Slide the pipe through the tank connector and tighten up so that the bottom of this last pipe is at the same level as pipe 2.

Go back and check the nuts on all 3 sets of pipework are all tightened up before filling the aquarium.

Installing the Filter Socks

The aquarium comes as standard with two 4 inch, 200 micron filter socks to remove any fine particles from the water which will polish the water. Silencing is fitted to reduce any water noise through the filters. The silencer sits above the socks with the two pipes facing downwards into the filters. As the filter socks block the water level will rise and when fully blocked will overflow the filter chamber.

The socks can simply be removed and washed through under the tap to clean them or can be replaced with new ones which are available from your retailer.

Roll Filter Option

If your aquarium is fitted with the optional Roll Filter option, which takes away the requirement for continuous cleaning of the filter bags, then please read the instructions that are supplied with the unit or visit our website for more information on installation and maintenance.

Initial testing of the pipework

When you fill the tank for the first time you can test that the pipework and tank connectors do not leak by first closing the valve on the syphon pipe and then filling the overflow box only, rather than the main aquarium. Check underneath for any weeping and if necessary tighten up any loose connections. Working this way gives you the option to remove the complete tank if necessary to correct any serious errors made during the pipework installation process.

Assuming no leaks, fully open up the syphon valve and continue to fill the aquarium.

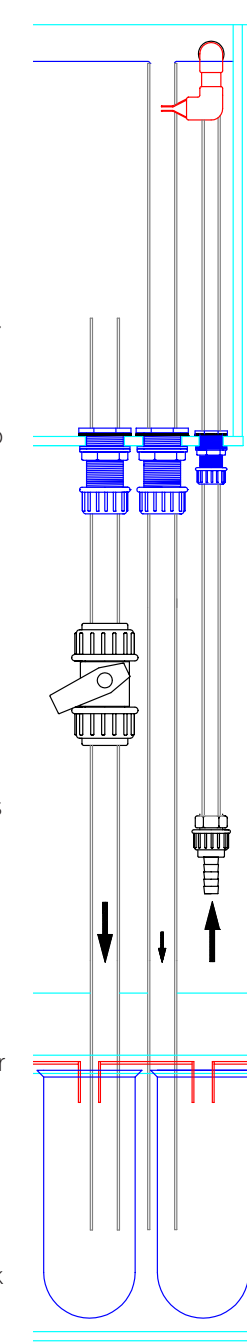

Sump Layout

The glass sump is designed to be flexible and have enough space to accommodate most types of equipment and methodologies. If you want to skim first before the refugeum or biological section or the other way round, this design will work for you either way.

Note: If installing an auto top-up unit, the float should be installed in section D

A - Pipe Section, B - Skimmer/Equipment Section, C - Equipment/ Refugeum Section, D - Pump Chamber, E - Top-up Reservoir

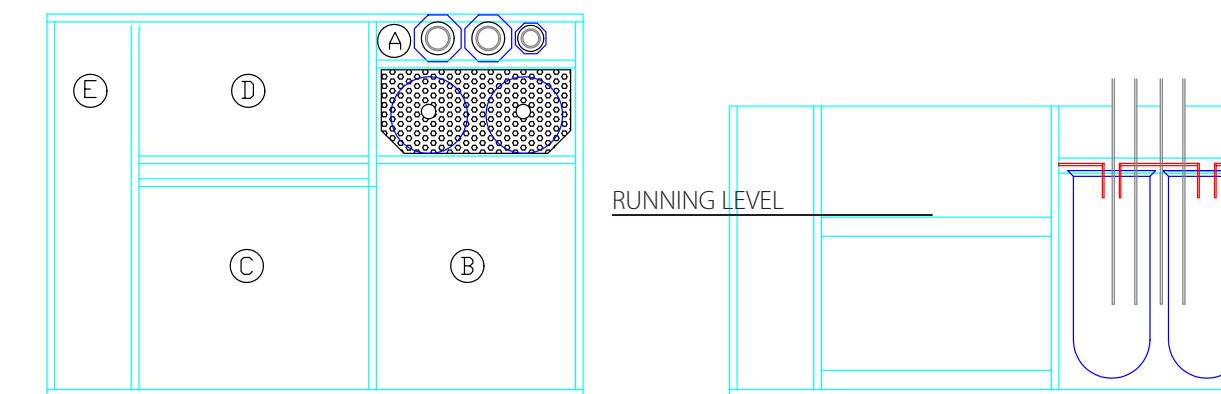

Silent Running of your Aquarium

Now that you have everything installed and piped up, you can start to fill the tank and let it overflow into the sump, up to the running level. Switch on the return pump and observe as the water fills the tank and then overflows into the weir box. Ensure that you keep the pump chamber filled up whilst this is happening. Initially the overflow will be noisy as the water gurgles down the syphon pipe.

Carefully close the shut off valve on pipe 3 until the gurgling stops and the water level in the weirbox starts to rise. Keep adjusting in small increments until the water only just dribbles down the emergency pipe, (pipe 2). This may take some fine tuning to achieve but will allow the overflow to run almost silently. It may be necessary to adjust this from time to time as the pipes and comb start to get dirty.

You will notice that there is an anti syphon hole in the feed pipe where it enters the tank and that you may get an initial water splutter from this on first starting. This is normal and will go away when the water level in the aquarium gets higher than the hole. It is important that this hole is kept clean and clear to prevent syphoning in the case of a power outage.

Levelling of the Doors.

As a final step you should know that the cabinet doors are fully adjustable in 3 planes. Remove the cover plate and adjust as per the diagram.

The hinges are lacquer coated to reduce corrosion however they should be wiped down from time to time, especially if they start to collect salt creep or get wet.

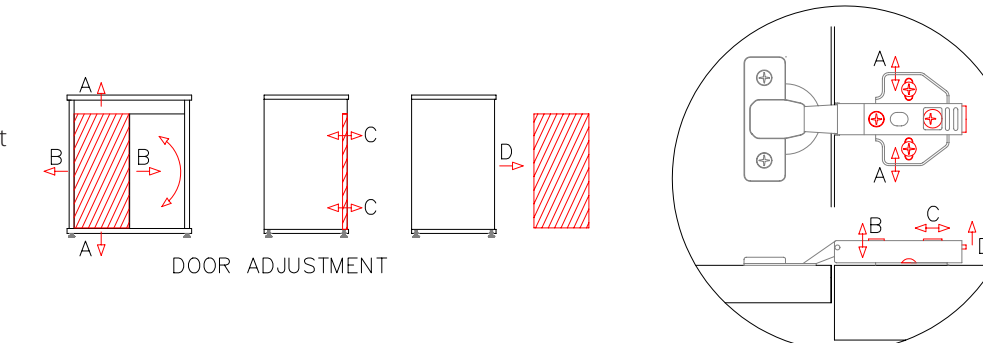

To compliment and benefit your new aquarium we recommend the following equipment and products...

Aquallumination Lighting
Take full control of the colours on your reef every minute of the day and night.



ANY APPLE OR ANDROID DEVICE

WiFi BUILT IN AI-FI



HYDRA52 HD
135W



HYDRA26 HD
90W



PRIME HD
55W

Light Mounting Options
For any Aquarium



D-D SLIMLINE BRACKET
FOR HYDRA26/52/VEGA

PRIME FLEX MOUNT

Deltec Protein Skimmer
SC1351



FMR75
Fluidised Reactor



H2Ocean Pro+
Reef Salt



RowaPhos
Phosphate Remover



DC Series Chillers
DC750



RECOMMENDED EQUIPMENT	REEF-PRO 900	REEF-PRO 1200	REEF-PRO 1500S
Return Pump Volume	2000-3000 litres/hour	3000-4000 litres/hour	3000-4000 litres/hour
Protein Skimmer	Deltec SC1351	Deltec SC1351	Deltec SC1456
Fluidised Reactor	FMR75	FMR75	FMR75
Chiller	DC300	DC300/DC750	DC750
LIGHTING OPTIONS			
Fish Only/Soft Corals/LPS	2 x PRIME HD	2/3 x PRIME HD	3 x PRIME HD
Mixed Reef/LPS/SPS	2 x HYDRA 26 HD	2 x HYDRA 26 HD	3 x HYDRA 26 HD
Heavily Stocked SPS	2 x HYDRA 26 HD	3 x HYDRA 26 HD / 2 x HYDRA 52 HD	3 x HYDRA 26 HD

REEF-PRO SPECIFICATION	RPA900	RPA1200	RPA1500S
SYSTEM			
System Volume	290 Litres	365 Litres	500 Litres
Tank Volume	225 litres	300 litres	425 litres
Sump Volume	65 litres	65 litres	75 litres
Top-Up Volume	17.5 litres	17.5 litres	22 litres
Overall Dimensions L/W/H (cm)	90 x 60 x 148	120 x 60 x 148	150 x 60 x 148
TANK			
Tank Dimensions L/W/H (cm)	90 x 60 x 46	120 x 60 x 46	150 x 60 x 56
Glass Thickness	12mm Low Iron	12mm Low Iron	15mm Low Iron
Back Glass Colour	Black	Black	Black
Weir Comb Length	330mm	330mm	330mm
Spare Weir Comb for Cleaning	✓	✓	✓
Overflow Pipes	2 x 32mm	2 x 32mm	2 x 32mm
Return Pipe	1 x 20mm	1 x 20mm	1 x 20mm
Adjustable Overflow Valve	✓	✓	✓
SUMP			
Systemised Glass Sump	✓	✓	✓
Filter Socks	2	2	2
Filter Silencing	✓	✓	✓
Skimmer/Equipment Chamber	✓	✓	✓
Refugium Chamber	✓	✓	✓
Pump Chamber	✓	✓	✓
CABINET			
Cabinet Dimensions L/W/H (cm)	90 x 60 x 102	120 x 60 x 102	150 x 60 x 92
Pre-assembled Construction	✓	✓	✓
Cabinet Finish	Visit Website	Visit Website	Visit Website
Chiller Section with Shelf		✓	✓
Adjustable feet	6	6	8
Quick Release Doors	✓	✓	✓

WE RESERVE THE RIGHT TO MODIFY AND IMPROVE OUR SPECIFICATIONS WITHOUT NOTICE.



Why not join our Facebook group to get inspiration and advice for your D-D Reef Pro Aquarium.

www.fb.com/groups/ddreefpro

H₂Ocean
ULTRA-FLOW

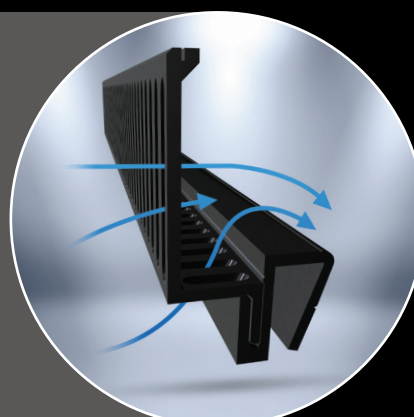

The D-D Reef Pro Aquariums feature our special **ULTRA-FLOW** Weir Comb.

Maintaining high flow through a standard weir comb isn't an easy task, weir boxes are usually designed to be as small and unobtrusive as possible and are normally restricted by a standard weir comb.

The D-D **ULTRA-FLOW** removable weir comb features horizontal and vertical drain slots allowing around 30-50% more water flow compared to a standard overflow comb. The higher flow through the weir comb also allows for higher output return pumps to be employed.

We even supply a spare comb section for use during cleaning.



FOLLOW US FOR
INSPIRATION!

TheAquariumSoln
fb.com/theaquariumsolution
plus.google.com/theaquariumsolution

www.theaquariumsolution.com

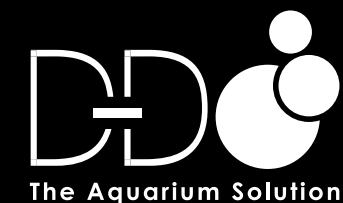

REEF-PRO AQUARIUM INSTALLATION INSTRUCTIONS

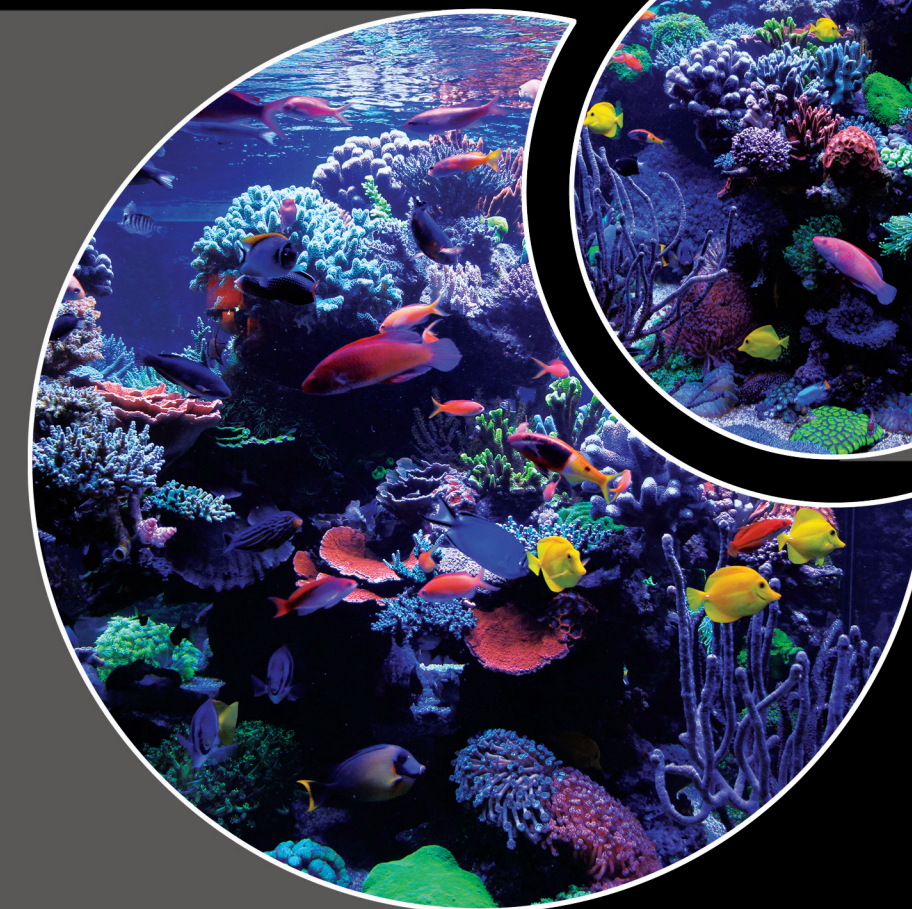

www.theaquariumsolution.com

D-D Reef-Pro Systemised Aquarium.

Please read the following installation instructions carefully before starting to assemble and run your aquarium. If correctly installed, your new aquarium should run silently and give you years of pleasure in this fantastic and enthralling hobby.

Preparation prior to delivery

Your Reef-Pro Aquarium when filled will be heavy!

Before taking delivery of your new **Reef-Pro Aquarium** you must first establish a suitable position for the system and ensure that the floor on which you are installing it on is suitable for the weight of the tank, cabinet, water and substrates without deforming or collapsing. If you are uncertain about whether your floor is strong enough please take professional advice.

Approximate Weights

MODEL	CABINET	TANK	SUMP	WATER	TOTAL	ADJUSTABLE FEET	PEOPLE REQUIRED
REEF-PRO 900	52 Kg	65 Kg	25 Kg	320 Kg	462 Kg	6	2
REEF-PRO 1200	68 Kg	79 Kg	25 Kg	400 Kg	572 Kg	6	2-4
REEF-PRO 1500S	98 Kg	133 Kg	30 Kg	590 Kg	851 Kg	8	4

Step 1 - Check Contents, Aquarium and Cabinet for Damage.

Your aquarium will arrive fully protected, and should be carefully unwrapped and checked for any damage. Use the contents diagram to ensure that there are no missing parts. Please report any issues immediately to your retailer.

Contents

